



# SOLAR LIGHTING

**SHENZHEN SRESKY CO.,LTD**

Address:JingMei Building,TaiWan industrial Park,

SHIYAN Town, BaoAn District, ShenZhen, China

Tel:+86-755-26902205 Fax:+86-755-26903022

Email: sales@sresky.com

Web: www.sresky.com www.sreskysolarlight.com



**SHENZHEN SRESKY CO.,LTD**

Address:JingMei Building,TaiWan industrial Park,

SHIYAN Town, BaoAn District, ShenZhen, China

Tel:+86-755-26902205 Fax:+86-755-26903022

Email: sales@sresky.com

Web: www.sresky.com www.sreskysolarlight.com

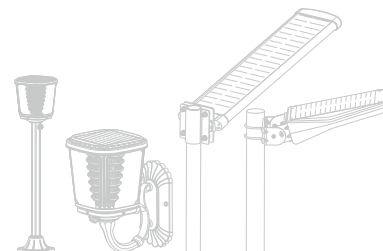

[WWW.SRESKY.COM](http://WWW.SRESKY.COM)

# SOLAR LIGHTING



*Solar our life.*

2017.07

# SOLAR LIGHTING



## PRODUCT RANGE

### Hot and Classic Series

- SSL Series
- TITANS Series
- HONOR Series
- Street Light Series
- Garden Light Series
- Wall Light Series
- Wall Washer Light Series





2015

SHENZHEN CHINA

# OUR OFFICE

PRETTY OFFICE ENVIRONMENT



## COMPANY PROFILE

**SRESKY** was established in 2004 and is located in Shenzhen City China. Covers an area of 13,000sqm, we employ 300 staff members and offer the monthly output of 50,000 units.

Our main products include solar street light, solar garden light, solar landscape light, solar plaza light, solar courtyard light, solar decoration light, solar wall light etc.

We have more than 70 different models in our range for you to choose from, due to our 15 innovative R&D team members who utilize their 8-15 years of industry experience to make us shine out from the competition.

With rich experience and expertise, we're able to develop 2-3 stylish solar lighting items each month.

We take QC seriously and employ 15 technicians who rigorously implement strict standards to ensure our products meet CE, FCC and RoHS directive standards. Because we operate according to an ERP management scheme, you can be confident that we're an efficient and professional company.

We have our own brand -"ESPZONE", and also, our R&D team can develop customized products according to your needs in 15 days.

Also, we are a certificated manufacturer by BV, SGS, ITS, BSCI, ISO and we welcome any kind of OEM and ODM projects!



SHENZHEN SRESKY CO.,LTD

## OUR CERTIFICATES



ISO9001

Intertek Report

SASO



CE Certification

FCC Certification

ROHS Certification

## OUR PATENT

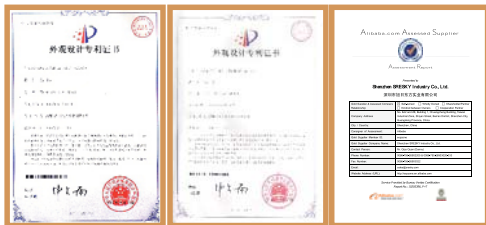

SLL-03 Patent

SGL-01 Patent

Supplier Assessment  
BV Report



SML-01 Patent

SML-02 Patent

ESL-24 Patent

## OUR FACTORY



WAREHOUSE

PRODUCTION LINE



TEST EQUIPMENT



Battery Aging Test

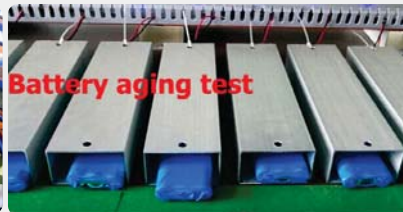

Battery aging test



LED aging testing



Outdoor Testing area



LED brightness test



Waterproof testing

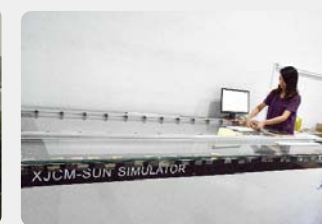

XJCM-SUN SIMULATOR



04

# TITANS SERIES

The Brightest Star in The Sky

There is always A best angle to get the most effective sunlight

*Solar our Life.*



# SSL- 28/27/26/25/24/23/22



## TITANS SERIES SOLAR STREET LIGHT

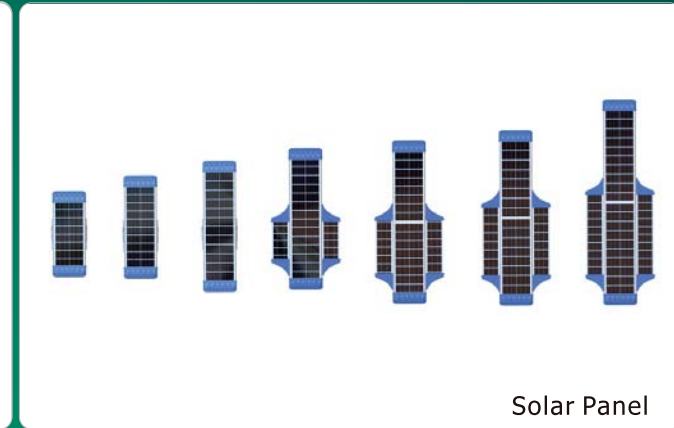
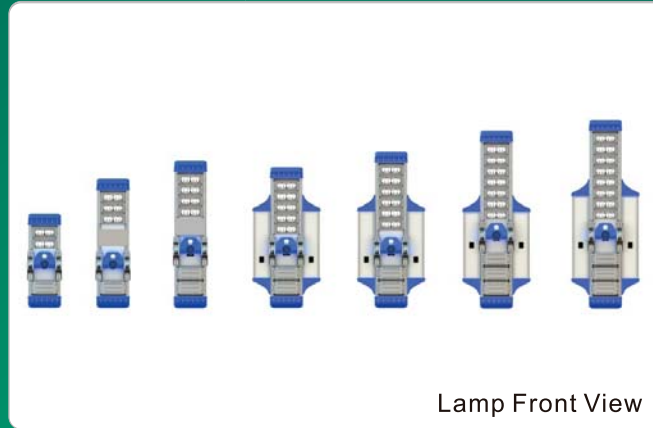
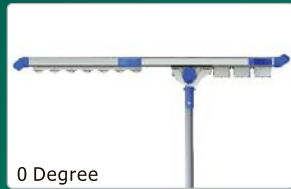

**SSL-28**  
2258\*810\*385mm

**SSL-27**  
2096\*810\*385mm

**SSL-26**  
1875\*810\*385mm

**SSL-25**  
1687\*810\*385mm

**SSL-24**  
1770\*421\*385mm

**SSL-23**  
1530\*421\*385mm

**SSL-22**  
1116\*421\*385mm

### Multi-Angle

-15,0,15,30 Four-degree angle to confirm the most effective charging efficiency. Professional Lighting distribution can keep the same angle while the Solar Panel angle changing.

### Patent

Professional Fresnel lens to achieve 20 m and 120 degree detectable area, far more than the competitor

### Features

Aircraft Carrier design to enlarge the solar panel and battery. Provide a longer lighting time

### Application

Street, Courtyard, Garden, Park, Roadway, pathway, Parking Lot, Campus, Farm & Ranch, Military Base

# TITANS SERIES Remote Control Solar Street Light

Different Angle and High efficiency Charge,  
Never Affected by the Installation Position.

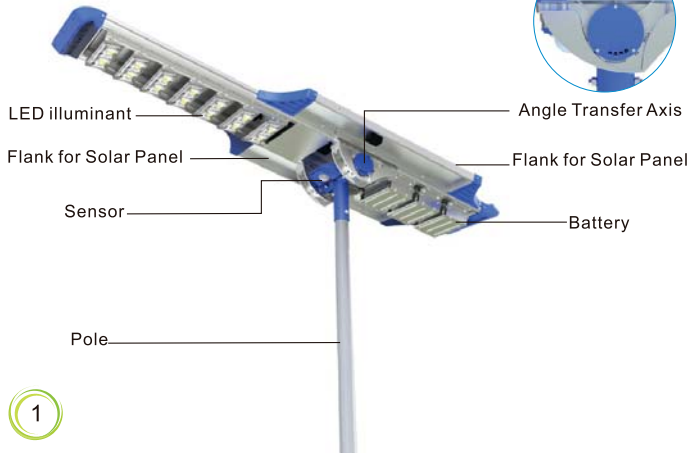

Model	SSL-22	SSL-23	SSL-24	SSL-25	SSL-26	SSL-27	SSL-28
LED	2000Lumens	3000Lumens	4000Lumens	5000Lumens	6000Lumens	7000Lumens	8000Lumens
Solar Panel	Monocrystalline silicon	Monocrystalline silicon	Monocrystalline silicon	Monocrystalline silicon	Monocrystalline silicon	Monocrystalline silicon	Monocrystalline silicon
Battery Type	Rechargeable Li-ion Battery	Rechargeable Li-ion Battery	Rechargeable Li-ion Battery	Rechargeable Li-ion Battery	Rechargeable Li-ion Battery	Rechargeable Li-ion Battery	Rechargeable Li-ion Battery
Solar Charging Time	9-10 hours by bright sunlight	9-10 hours by bright sunlight	9-10 hours by bright sunlight	10 hours by bright sunlight	10 hours by bright sunlight	10 hours by bright sunlight	10 hours by bright sunlight
Lighting Time	3 Nights after fully Charged	3 Nights after fully Charged	3 Nights after fully Charged	3 Nights after fully Charged	3 Nights after fully Charged	3 Nights after fully Charged	3 Nights after fully Charged
Lighting Mode	RemoteControl for Brightness and Winter/SummerMode Selection	RemoteControl for Brightness and Winter/SummerMode Selection	RemoteControl for Brightness and Winter/SummerMode Selection	RemoteControl for Brightness and Winter/SummerMode Selection	RemoteControl for Brightness and Winter/SummerMode Selection	Remote Control for Brightness and Winter/SummerMode Selection	Remote Control for Brightness and Winter/SummerMode Selection
Material	Aluminumalloy + PC	Aluminumalloy + PC	Aluminumalloy + PC	Aluminumalloy + PC	Aluminumalloy + PC	Aluminumalloy + PC	Aluminumalloy + PC
Waterproof	IP65	IP65	IP65	IP65	IP65	IP65	IP65
Product Size	1116*421*385mm	1530*421*385mm	1770*421*385mm	1687*810*385mm	1875*810*385mm	2096*810*385mm	2258*810*385mm
Application	Street,Courtyard,Garden, Park,Roadway,pathway,Parking Lot,Campus,Farm & Ranch,Military Base						

# HONOR

AS TIME GOES BY, ONLY THE  
CLASSIC FOREVER

# SERIES

ALWAYS HERE

- SLL-10 Series
- SLL-11 Series
- SLL-18 Series



You are right! It's solar light with invisible solar panel!



# SLL-10 SERIES



## HONOR SERIES SOLAR LANDSCAPE LIGHT



2.5M

3M

3M

3-3.5M

2.5M -3M- 3.5M is the Recommended installation height

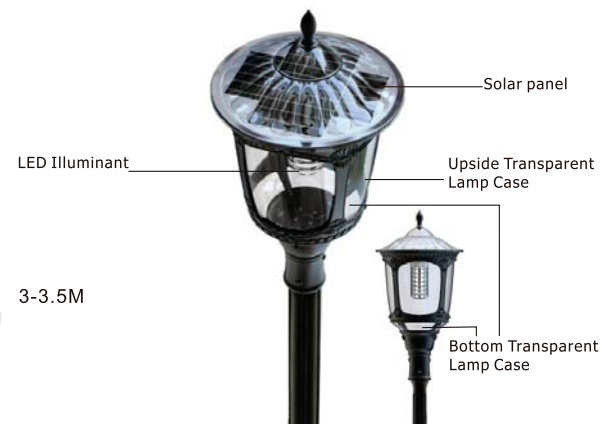

Model	SLL-10	SLL-10-1 Multi-Lamp
LED	2000 Lumens	N*2000 Lumens
Solar Panel	Monocrystalline silicon	Monocrystalline silicon
Battery Type	Rechargeable Li-ion Battery	Rechargeable Li-ion Battery
Solar Charging Time	5-6 hours by bright sunlight	5-6 hours by bright sunlight
Lighting Time	3 Nights after fully Charged	3 Nights after fully Charged
Lighting Mode	5H 25%+5H 10% , PIR Sensors 100% 30S	5H 25%+5H 10% ,PIR Sensors 100% 30S Multi Wireless sync control
Material	Aluminum alloy + PC	Aluminum alloy + PC
Waterproof	IP65	IP65
Product Size	∅416*830mm	∅416*830mm
Application	Garden, Gate, Fence, Courtyard, Road, Park, Pathway etc	

# SLL-11 SERIES



## HONOR SERIES SOLAR LANDSCAPE LIGHT



2.5M



3M



3M



3-3.5M



Model	SLL-11	SLL-11-1 Multi-Lamp
LED	2000 Lumens	N*2000 Lumens
Solar Panel	Monocrystalline silicon	Monocrystalline silicon
Battery Type	Rechargeable Li-ion Battery	Rechargeable Li-ion Battery
Solar Charging Time	5-6 hours by bright sunlight	5-6 hours by bright sunlight
Lighting Time	3 Nights after fully Charged	3 Nights after fully Charged
Lighting Mode	5H 25%+5H 10% , PIR Sensors 100% 30S	5H 25%+5H 10% ,PIR Sensors 100% 30S Multi Wireless sync control
Material	Aluminumalloy + PC	Aluminumalloy + PC
Waterproof	IP65	IP65
Product Size	Φ416*808mm	Φ416*808mm
Application	Garden, Gate, Fence, Courtyard, Road, Park, Pathway etc	

2.5M -3M- 3.5-4M is the Recommended installation height

# Solar Street Light Series

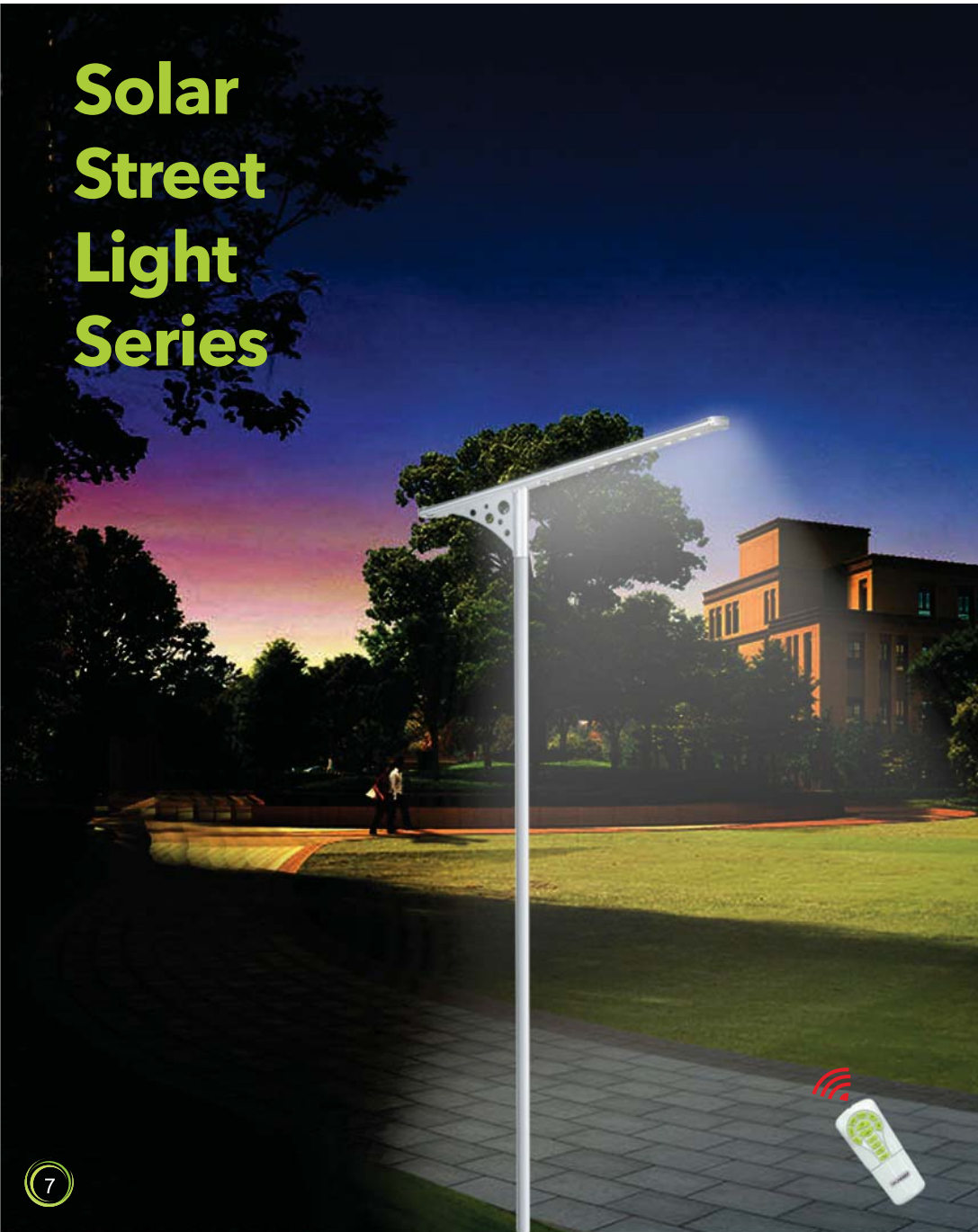

## SSL-06R/07R/08R



**Upgrade Product**

### Remote Control Solar Street Light --Make You Feel the World is So Bright



Model	SSL-06R	SSL-07R	SSL-08R
LED	3000 Lumens	4500 Lumens	6000 Lumens
Solar Panel	Monocrystalline silicon	Monocrystalline silicon	Monocrystalline silicon
Battery Type	Rechargeable Li-ion Battery	Rechargeable Li-ion Battery	Rechargeable Li-ion Battery
Solar Charging Time	9-10 hours by bright sunlight	9-10 hours by bright sunlight	10 hours by bright sunlight
Lighting Time	3 Nights after fully Charged	3 Nights after fully Charged	3 Nights after fully Charged
Lighting Mode	RemoteControl+Time Control+PIR Motion Sensor	RemoteControl+Time Control+PIR Motion Sensor	RemoteControl+Time Control+PIR Motion Sensor
Material	Aluminumalloy + PC	Aluminumalloy + PC	Aluminumalloy + PC
Waterproof	IP65	IP65	IP65
Product Size	773*225*287mm	1043*225*287mm	1511*225*161mm
Application	Street,Courtyard,Garden, Park,Roadway,pathway,Parking Lot,Campus,Farm& Ranch,Military Base.		

# Solar Street Light Series

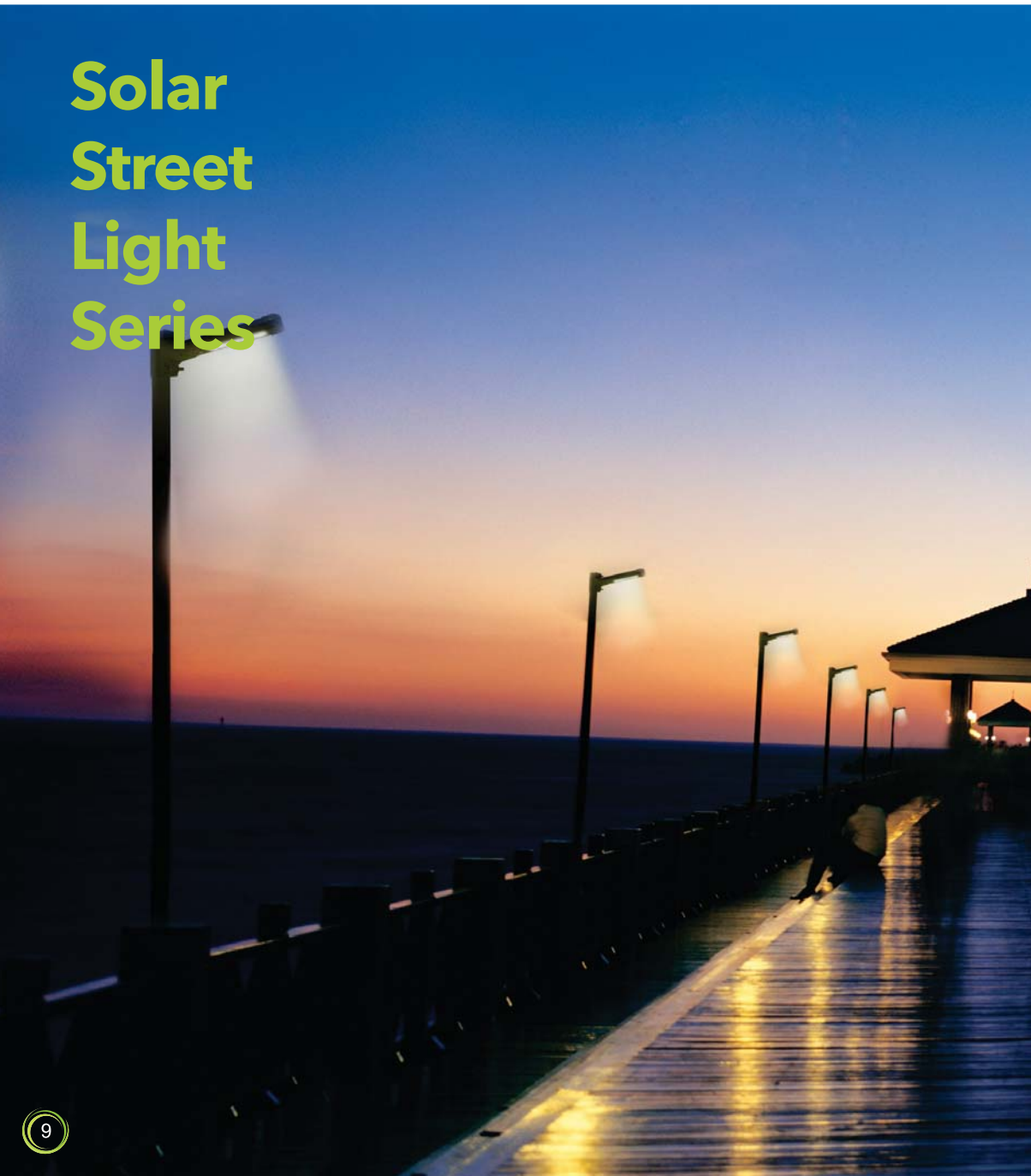

SSL-01/05



## All In One Solar Street Courtyard Light

—The Fashion, the Whole World Deserve It.



SSL-01

SSL-05



### Specification

Model	SSL-01	SSL-05
LED	1000Lumens	8000Lumens
Battery Type	Rechargeable Li-ion Battery	Rechargeable Li-ion battery
Solar Panel	Monocrystalline silicon	Monocrystalline silicon
Install height	2.5~3meters	6~8M
Solar charging time	11 hours by bright sunlight	10~11 hours by bright sunlight
Lighting time	3 nights	Over 3 nights
Lighting mode	300 lumens for first 5 hrs +150 lumens DIM light with PIR 1000 lumens full brightness till dawn	1000 lumens DIM light with PIR 8000 lumens full brightness till dawn
Waterproof	IP 65	IP65
Material	Aluminum alloy +Tempered Glass	
Size	505*227*164mm	1933*420.5*224.5 mm
Application	Street,Courtyard,Garden,Park, Roadway,Pathway,Parking Lot,Privateroad, Sidewalk,Public square, plaza,Campus,Airfield,Farm & Ranch,Perimeter Security, Wildlife area,Remote Area,Military Base	

**ESL-20/30/40**



**All-in-One Solar street LED light**

**--Best Choice for Government Project.**



ESL-20



ESL-30



ESL-40



**Specification**

Model	ESL-20	ESL-30	ESL-40
LED	2000Lumens	3000Lumens	4000Lumens
Battery Type	Rechargeable Li-ion Battery	Rechargeable Li-ion Battery	Rechargeable Li-ion Battery
Solar Panel	Monocrystalline silicon	Monocrystalline silicon	Monocrystalline silicon
Install height	4~5 meters	4~6 meters	6~8 meters
Solar charging time	12 hours by bright sunlight	10 hours by bright sunlight	10~11 hours by bright sunlight
Lighting time	3 nights	3 nights	3 nights
Lighting mode	5Hrs 100% light+ 25% light till dawn	5Hrs 100% light+ 25% light till dawn	5Hrs 100% light+ 25% light till dawn
Waterproof	IP 65	IP 65	IP 65
Material	Aluminum alloy + Tempered Glass		
Size	1092*488*117mm	1092*488*117mm	1308*488*117mm
Application	Street, Government project, Garden, Courtyard, Roadway, Pathway, Public square, Campus, Parking lot		



# Solar Plaza Light Series



SLL-12/14/16



**Remote Control**  
**Solar plaza light**  
**--Best Choice for Landscape Project**



Specification			
Model	SLL-12	SLL-14	SLL-16
LED	2000Lumens	3000Lumens	5000Lumens
Battery Type	Rechargeable Li-ion Battery	Rechargeable Li-ion Battery	Rechargeable Li-ion Battery
Solar Panel	Monocrystalline silicon	Monocrystalline silicon	Monocrystalline silicon
Install height	3~4 meters	3~5 meters	4~6 meters
Solar charging time	8-9 Hours by Bright Sunlight	9 Hours by Bright Sunlight	12 - 13 Hours by Bright Sunlight
Lighting time	3 Nights after Fully Charged	3 Nights after Fully Charged	3 Nights after Fully Charged
Lighting mode	Remote Control + Timer Function	Remote Control + Timer Function	Remote Control + Timer Function
Waterproof	IP 65	IP 65	IP 65
Material	Aluminum alloy+ABS	Aluminum alloy+ABS	Aluminum alloy+ABS
Size	525*525*161mm	690*727*223 mm	935*905*234mm
Application	Courtyard, Garden, Park, Street, Roadway, Pathway, Parking Lot, Private Road, Sidewalk, Public Square, Plaza, Campus, Airfield, Farm, Ranch & Ranch, Perimeter Security, Wildlife Area, Remote Area, Military Base		

**Professional Lighting Distribution for Government Project**

## SCL-01



### Remote controller + Solar Courtyard Light



Specification	
LED	1000Lumens
Solar panel	Monocrystalline silicon
Battery Type	Rechargeable Li-ion Battery
Solar charging time	9-10 Hrs by bright sunlight
Lighting time	3 Nights after fully Charged
Lighting mode	15%-50%-100% by PIR and controller
Material	Aluminum alloy + PC
Waterproof	IP65
Product size	446*247*86mm
Application	Garden, Courtyard



## SLL-06



### Solar Landscape Light



Specification	
LED	1000Lumens
Solar panel	Monocrystalline silicon
Battery Type	Li-ion rechargeable battery
Solar charging time	10 hours by bright sunlight
Lighting time	3 nights
Lighting mode	5Hrs 100% light+25% light till dawn
Material	Aluminum alloy + PC
Waterproof	IP65
Product size	512*512*482mm
Application	Plaza, Public Square, Courtyard, Garden, Park, Street, Roadway, pathway, Parking Lot, Private road, Sidewalk, Campus, Airfield, Farm & Ranch



## UPGRADE PRODUCTS



### Specification

LED	2500lumens
Solar panel	Monocrystalline silicon
Battery Type	Li-ion rechargeable battery
Solar charging time	5-6 hours by bright sunlight
Lighting time	3 nights
Lighting mode	DIM Light+Motion Sensor+ Remote Control
Material	Aluminum + ABS
Install height	3 meters
Waterproof	IP 65
Product size	752*459*153mm
Application	Courtyard, Garden, Park, Street, Roadway, pathway, Parking Lot, Private road, Sidewalk, Public square, plaza, Campus, Airfield, Farm & Ranch, Perimeter Security, Wildlife area, Remote Area, Military Base

## SDL-01



### Solar Landscape Light

# Solar Garden Light Series

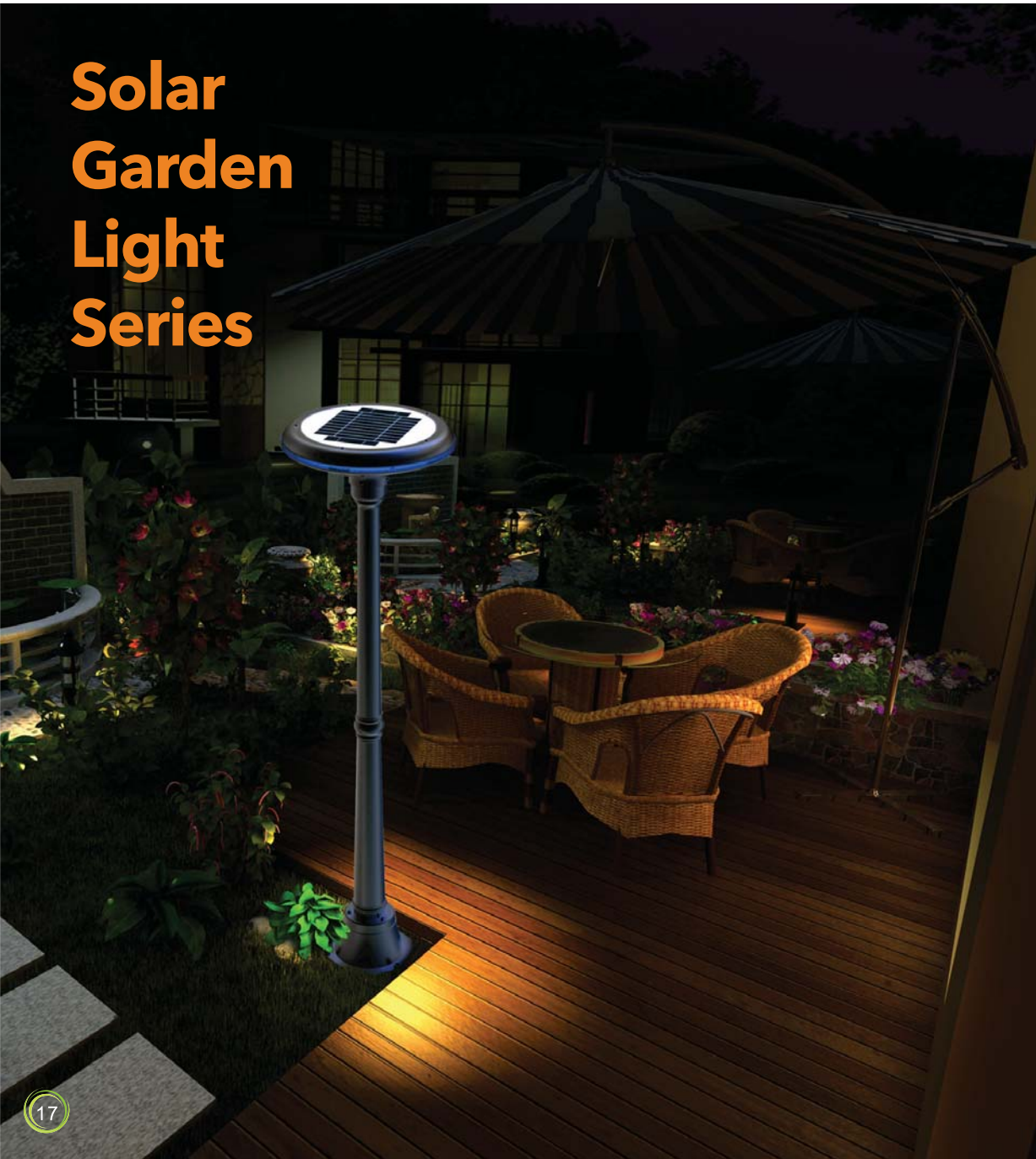

**SGL-05/SCL-02**



**Solar Garden Light**

**--Life itself can be So Romantic**



SGL-05



SCL-02

**Specification**

LED	150Lumens	150Lumens
Solar panel	Monocrystalline silicon	Monocrystalline silicon
Battery Type	Rechargeable Li-ion Battery	Rechargeable Li-ion Battery
Solar charging time	7-8 Hrs by bright sunlight	7-8 Hrs by bright sunlight
Lighting time	3 Nights after fully Charged	3 Nights after fully Charged
Lighting mode	5Hrs high brightness + 7 Hrs dim light	5Hrs high brightness + 7 Hrs dim light
Material	Aluminum alloy + PC	Aluminum alloy + PC
Waterproof	IP65	IP65
Product size	320*320*818mm	320*320*1496mm
Application	Garden, Courtyard, Road, Park, Street, Pathway	

**150 LUMENS**



SLL-07



Solar Landscape Light



Specification	
LED	1200Lumens
Solar panel	Monocrystalline silicon
Battery Type	Rechargeable Li-ion Battery
Solar charging time	12 hours by bright sunlight
Lighting time	3 Nights after fully Charged
Lighting mode	DIM lighting + Sensor for Bright Light
Material	Aluminum alloy + PC
Waterproof	IP65
Product size	330*330*529mm
Application	Garden, Courtyard, Road, Park, Street, Pathway



SGL-01/02



European-style Solar Garden Light



Specification		
Model	SGL-01	SGL-02
LED	100Lumens	200Lumens
Battery Type	Rechargeable Li-ion battery	Rechargeable Li-ion battery
Solar panel	Monocrystalline silicon	Monocrystalline silicon
Solar charging time	7-8 hours by bright sunlight	7-8 hours by bright sunlight
Lighting time	3 nights after fully charged	3 nights after fully charged
Lighting mode	High brightness for whole night	DIM lighting + PIR motion Sensor for Bright Lighting
Material	Aluminum+PC	Aluminum+PC
Waterproof	IP65	IP65
Product size	176 *176 *277mm	176 *176 *802mm
Application	Garden, Courtyard, Road, Park, Hotel, Pathway etc	

SDL-02



Solar Garden Light



Specification	
LED	20Lumens
Solar panel	Monocrystalline silicon
Battery Type	Rechargeable Li-ion Battery
Solar charging time	9-10Hrs by bright sunlight
Lighting time	3 Nights after fully Charged
Lighting mode	High Light for 8 Hours Per Night
Material	Aluminum alloy + PC
Waterproof	IP65
Product size	Diameter 124mm, Pole:620mm
Application	Garden, Courtyard, Park,lawn, Swimming pool



SGL-03/04



European-style Solar Garden Light



Specification		
Model	SGL-03	SGL-04
LED	200Lumens	200Lumens
Battery Type	Rechargeable Li-ion battery	Rechargeable Li-ion battery
Solar panel	Monocrystalline silicon	Monocrystalline silicon
Solar charging time	7-8 hours by bright sunlight	7-8 hours by bright sunlight
Lighting time	3 nights after fully charged	3 nights after fully charged
Lighting mode	DIM lighting + PIR motion Sensor for Bright Lighting	DIM lighting + PIR motion Sensor for Bright Lighting
Material	Aluminum+PC	Aluminum+PC
Waterproof	IP65	IP65
Product size	176 *176 *438mm	250 *176 *298mm
Application	Garden, Courtyard, Road, Park, Hotel, Pathway etc	

SWL-01



Pull Switch Solar Motion Light



Specification	
LED	1000 Lumens
Solar panel	Monocrystalline silicon
Battery Type	Rechargeable Li-ion Battery
Solar charging time	8 - 9 Hours by Bright Sunlight
Lighting time	3 Nights after Fully Charged
Lighting mode	Pull Switch + Dim Light + PIR Motion Sensor
Material	Aluminum Alloy + ABS
Install height	2-3M
Waterproof	IP65
Product size	282*185*205mm
Application	Warehouse, Courtyard, Community, Parking Lot Wall, Building Wall, Garden, Park, Square, Pathway, etc.



SWL-02



Pull Switch Solar Motion Light



Specification	
LED	400Lumens
Solar panel	Monocrystalline silicon
Battery Type	Rechargeable Li-ion Battery
Solar charging time	9 - 10 Hours by Bright Sunlight
Lighting time	3 Nights after Fully Charged
Lighting mode	Pull Switch + Dim Light + PIR Motion Sensor
Material	ABS+PC
Waterproof	IP65
Install height	2-3M
Product size	131*234*101mm
Application	Warehouse, Courtyard, Community, Parking Lot Wall, Building Wall, Garden, Park, Square, Pathway, etc.



ESL-15/25



Solar Garden Light



Model	Specification	
	ESL-15	ESL-25
LED	100Lumens	100Lumens
Solar panel	Monocrystalline silicon	Monocrystalline silicon
Battery Type	Li-ion rechargeable battery	Li-ion rechargeable battery
Solar charging time	7~8 hours by bright sunlight	7~8 hours by bright sunlight
Lighting time	Around 3 nights	Around 3 nights
Lighting mode	5Hrs high brightness + 7Hrs dim light	5Hrs high brightness + 7Hrs dim light
Material	Aluminum alloy+ABS+PC	Aluminum alloy+ABS+PC
Waterproof	IP65	IP65
Product size	160*160*264mm	160*160*800mm
Application	Garden, Courtyard, Road, Park, Street, Pathway	

SLL-05/SLL-15



Solar underground light

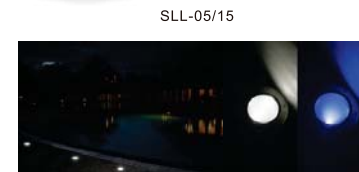

Model	Specification		
	ESL-01	SLL-05	SLL-15
LED	20Lumens	30Lumens	30Lumens
Solar panel	Monocrystalline silicon	Monocrystalline silicon	Monocrystalline silicon
Battery Type	Li-ion rechargeable battery	Li-ion rechargeable battery	Li-ion rechargeable battery
Solar charging time	7 hours by bright sunlight	11 hours by bright sunlight	11 hours by bright sunlight
Lighting time	High bright light 50Hrs	3 nights after fully charged	3 nights after fully charged
Lighting mode	High brightness for whole night	First 5 hours white color light, when something pass by above the lamp (distance 0-50CM), it will turn to blue color for 5-10 second. After the first 5 hours,color switch sensor will turn off automatically and the lamp keep white color in 50% DIM light. After 10 hours lighting, the lamp will be off automatically.	
Material	Aluminum alloy +Tempered Glass		
Waterproof	IP68	IP68	IP68
Product size	Φ128*58mm	Φ170*55mm	Φ170*55mm
Application	Plaza, Park, Garden, Street, Walkway, Bank of swimming pool etc.		



## SML-02 Solar Motion Light with Warm White and Pure White Light



Specification	
LED	200Lumens
Solar panel	Monocrystalline silicon
Battery Type	Li-ion rechargeable battery
Solar charging time	12 hours by bright sunlight
Lighting time	Over 3 nights
Lighting mode	Warm White Dim Lighting +Motion Sensor for Bright Pure White Lighting
Material	ABS+PC
Install height	2~3M
Waterproof	IP65
Product size	N/A
Application	Garden, Courtyard, Road,Park, Street,Pathway



SML-01

SML-01T



## Remote Control Solar PIR Security Light



Specification		
Model	SML-01	SML-01T
LED	1000Lumens	1000Lumens
Solar panel	Monocrystalline silicon, 17% efficiency	Monocrystalline silicon, 17% efficiency
Battery Type	Li-ion rechargeable battery	Li-ion rechargeable battery
Solar charging time	11 hours by bright sunlight	11 hours by bright sunlight
Lighting time	More than 5 nights	More than 5 nights
Lighting mode	Dark/DIM/Bright	Dark/DIM/Bright
Material	Aluminum alloy +Tempered Glass	
Install height	2.5~3.5M	2.5~3.5M
Waterproof	IP65	IP65
Product size	242.5*120.5*92mm	242.5*120.5*92mm
Application	Warehouse,Garden, park, courtyard,community, building,Wall ,etc	



## ESL-06 Solar Step Light



Specification	
LED	20Lumens
Solar panel	Monocrystalline silicon
Battery Type	Li-ion rechargeable battery
Solar charging time	12 hours by bright sunlight
Lighting time	Over 3 nights
Lighting mode	High brightness for the hole night
Material	Aluminum+ABS
Waterproof	IP65
Product size	200*123*63mm
Application	Wall, Step, Road, Garden, Park, Square, Street , Pathway



## SLL-02 RGB Solar Flood Light



Specification	
LED	3W RGB LED
Solar panel	Monocrystalline silicon
Battery Type	Li-ion rechargeable battery
Solar charging time	8~9 hours by bright sunlight
Lighting time	2 nights
Lighting mode	5 hours 100% brightness and then 3 hours 50%, 8 hours per night. Red,Orange, Yellow,Green,Green Grass,Blue, Purple, Seven Colors Switch
Material	Aluminum alloy + Tempered Glass
Install height	N/A
Waterproof	IP65
Product size	242.5*120.5*92mm
Application	Courtyard,Garden, Park,Street,Roadway,pathway,Parking Lot,Private road,Sidewalk,Public square,plaza,Campus,Airfield,Farm & Ranch, Perimeter Security,Wildlife area,Remote Area,Military Base



东桥鸟瞰



# Solar Wall Washer Series

Apply to Bridge, Building,  
Advertisement Board,  
Outdoor Step, Roof,  
Fence etc.



**SLL-17**



**Solar Wall Washer Light**

**400 LUMENS**



Specification	
LED	400 lumens
Solar panel	Monocrystalline silicon
Battery Type	Rechargeable Li-ion Battery
Solar charging time	6-7 hours by bright sunlight
Lighting time	3 Nights after fully Charged
Lighting mode	5Hrs high brightness + 3 Hrs dim light
Material	Aluminum alloy + PC
Waterproof	IP65
Product size	1022*128*108mm
Application	Garden,Hotel,Overpass, Bridge,Building External Wall , Yard,Square,Pathway,etc

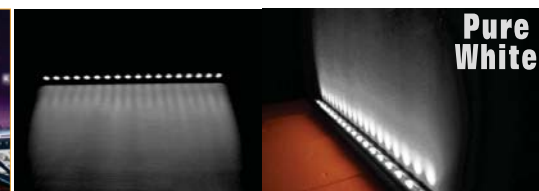

**SLL-08**



**Solar Wall Washer Light**



**200 LUMENS**

Specification	
LED	200 lumens
Solar panel	Monocrystalline silicon
Battery Type	Rechargeable Li-ion Battery
Solar charging time	6-7 hours by bright sunlight
Lighting time	3 Nights after fully Charged
Lighting mode	5Hrs high brightness + 3 Hrs dim light
Material	Aluminum alloy + PC
Waterproof	IP65
Product size	517*108*128mm
Application	Garden,Hotel,Overpass, Bridge,Building External Wall , Yard,Square,Pathway,etc

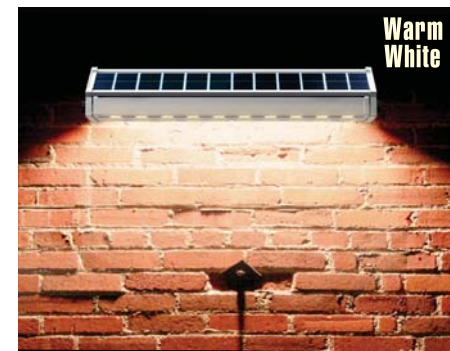

# SSL-13/14/15/16/17/18/19/20

## Solar High Mast Light



SSL-13

SSL-14



SSL-15

SSL-16



SSL-17

SSL-18



SSL-19

SSL-20



15 Degree

0 Degree

Model	SSL-13	SSL-14	SSL-15	SSL-16	SSL-17	SSL-18	SSL-19	SSL-20
LED	14000 Lumens	14000 Lumens	21000 Lumens	21000 Lumens	25000 Lumens	25000 Lumens	32000 Lumens	32000 Lumens
Solar Panel	Monocrystalline Silicon	Monocrystalline Silicon	Monocrystalline Silicon	Monocrystalline Silicon	Monocrystalline Silicon	Monocrystalline Silicon	Monocrystalline Silicon	Monocrystalline Silicon
Battery Type	Rechargeable Li-ion Battery	Rechargeable Li-ion Battery	Rechargeable Li-ion Battery	Rechargeable Li-ion Battery	Rechargeable Li-ion Battery	Rechargeable Li-ion Battery	Rechargeable Li-ion Battery	Rechargeable Li-ion Battery
Solar Charging Time	10 - 12 Hours by Bright Sunlight	10 - 12 Hours by Bright Sunlight	10 - 12 Hours by Bright Sunlight	10 - 12 Hours by Bright Sunlight	10 - 12 Hours by Bright Sunlight	10 - 12 Hours by Bright Sunlight	10 - 12 Hours by Bright Sunlight	10 - 12 Hours by Bright Sunlight
Lighting Time	3 Nights after fully Charged	3 Nights after fully Charged	3 Nights after fully Charged	3 Nights after fully Charged	3 Nights after fully Charged	3 Nights after fully Charged	3 Nights after fully Charged	3 Nights after fully Charged
Lighting Mode	Wireless Control + Timer	Wireless Control + Timer	Wireless Control + Timer	Wireless Control + Timer	Wireless Control + Timer	Wireless Control + Timer	Wireless Control + Timer	Wireless Control + Timer
Material	Aluminum Alloy + PC	Aluminum alloy + PC	Aluminum alloy + PC	Aluminum alloy + PC	Aluminum alloy + PC	Aluminum alloy + PC	Aluminum alloy + PC	Aluminum alloy + PC
Waterproof	IP65	IP65	IP65	IP65	IP65	IP65	IP65	IP65
Product Size	1020*1020mm	1020*1020mm	1650*1020mm	1650*1020mm	1330*1330mm	1330*1330mm	1490*1490mm	1490*1490mm
Application	Public Square, Stadium, Parking Lot, Farm & Ranch, Mining Area, Port Wharf, Highway Exit, Highway Crossroad, Airport, Military Base							

SSL-10/11/12



## Remote Control Solar Street Light



Model	SSL-12	SSL-11	SSL-10
LED	6000 Lumens	4000 Lumens	2000 Lumens
Solar Panel	Monocrystalline Silicon	Monocrystalline Silicon	Monocrystalline Silicon
Battery Type	Rechargeable Li-ion Battery	Rechargeable Li-ion Battery	Rechargeable Li-ion Battery
Solar Charging Time	12 Hours by Bright Sunlight	11 Hours by Bright Sunlight	11 Hours by Bright Sunlight
Lighting Time	3 Nights after fully Charged	3 Nights after fully Charged	3 Nights after fully Charged
Lighting Mode	Remote Control + PIR Motion Sensor	Remote Control + PIR Motion Sensor	Remote Control + PIR Motion Sensor
Material	Aluminumalloy + PC	Aluminumalloy + PC	Aluminumalloy + PC
Waterproof	IP65	IP65	IP65
Product Size	1213*299*243mm	908*299*243mm	608*299*243mm
Application	Street, Courtyard, Garden, Park, Roadway, Pathway, Parking, Lot, Campus, Farm & Ranch, Military Base		



More Popular Solar products, please visit <http://www.sreskysolarlight.com> <http://www.sresky.com>

### Some of our Exhibition



2012 South African Solar show



2013 Apri Hong-Kong Solar show



2014 Brazil International Lighting Industry Exhibition



2014 Mexico Expoelectrica Internacional



2014 Year Dubai International Design Exhibition



2015 Abu Dhabi National Exhibition



2015 Dubai Light Middle East



2015 SOLAR-TEC in Egypt



2015 Canton Fair



2015 Germany Intersolar Fair



2015 UK Fair



2015 Solar World Africa



2016 POGEE Pakistan



2016 SOLARED Istanbul Turkey



2016 Saudi Power